



## Reference Manual - Installation



**Product :** Modular Roof Rack

**Part # :** 004-A263A

**Application :** Dodge RAM Promaster 159-X HR (2014+)

**Difficulty :** 1 2 **3** 4 5

**Installation time :** 3 to 4 hours (without solar panels)

4 to 6 hours (with solar panels)

**Make the road your home.**

[www.remoraco.com](http://www.remoraco.com)

# Index

<b>P2</b>	INDEX
<b>P3</b>	PRECAUTIONS ET RECOMMANDATIONS
<b>P4-5</b>	WARNINGS
<b>P6</b>	REQUIRED TOOLS

## INSTALLATION STEPS

<b>P8</b>	ROOF MOUNT INSTALLATION
<b>P9-10</b>	ROOF MOUNT POSITIONING LAYOUT - <i>RAM PROMASTER 159X-HR</i>
<b>P11-13</b>	SIDE PLATE & JOINER PLATE INSTALLATION
<b>P14-17</b>	SOLAR PANEL & CROSSBAR INSTALLATION
<b>P18-19</b>	WIND FAIRING BRACKET INSTALLATION (ON FRONT CROSSBAR)
<b>P20</b>	CROSSBAR TIGHTENING
<b>P21</b>	ALIGNMENT & FINAL TIGHTENING
<b>P22</b>	T-NUT INSTALLATION ON CROSSBARS
<b>P23</b>	WIND FAIRING INSTALLATION

## Preparation

### Precautions & recommendations

#### **A few precautions for a smooth installation**

- \* We recommend that you protect the roof of your vehicle with a blanket or large cardboard box, to prevent from scratching your roof with free moving parts during installation.
- \* Be careful; you will perform tasks from 8'+ heights. Be supervised at all times or secured with a harness during installation. An 8' or higher stepladder is necessary.
- \* We recommend that you securely place all the necessary components and tools on the (protected) roof of your vehicle. This will make it much easier to install directly on the roof with everything at hand.
- \* In order to considerably reduce installation time, we recommend the use of two good quality 8'+ stepladders, placed on each side of your vehicle.
- \* At any time, if you have any doubts about the installation, stop immediately and contact our customer service department.

## Preparation

### Warnings



### Warnings

! Some components of the product have sharp edges. Please handle with care and remain aware of your surroundings to avoid any scratching or damage to your vehicle.

! Tighten all hardware by hand using a torque wrench or torque adaptor. Since the components are made of aluminum, the use of an “impact”, battery or electric screwdriver could damage the threads of the components and render the product unusable.

! Perform the final tightening of the roof anchor hardware at the very end of the installation. Since this hardware is made up of “NyLock” type nylon lock nuts, it is not recommended to tighten and loosen these nuts more than once, as this may crack or cut the bolts. These nuts are of single use. The final tightening must therefore be done only once, at the very end of your installation.

! For any hardware that does not use “NyLock” type nylon lock nuts, apply a drop of blue Loctite (provided in your hardware box) on the bolt threads. (Wind fairing hardware for deflector & crossbar hardware)

! To avoid the appearance of scratches or premature wear of the paint under the wind fairing, caused by using the vehicle in sandy “off-road” environments, or by insufficient cleaning of the sand, dirt, dust or abrasive elements under the deflector, it is important to apply the protective paint films (supplied) to the suitable places on your body, under the wind fairing rubber edge trims. Regular inspection of the product and the underside of the deflector is necessary to ensure the correct positioning of the fairing and protective paint films.

! Under road, wind and pothole vibration, the product and its components may slightly move and self-adjust. Perform a regular check once every season change to ensure the good condition and correct positioning of the components. Check the anchoring hardware and installation hardware after the first 20 and 200 kilometers traveled and adjusting the hardware torque if needed. Also perform a routine check of all product hardware.

! Installation and removal of the roof rack and its components should always be performed by two or more people.

...

## Preparation

### Warnings



## Warnings (part 2)

! As it is difficult to predict the thousands of different configurations with the hundreds, if not thousands of component choices currently available on the market, installing a modular rack, roof fans and other components on the roof of your vehicle can cause or accentuate in certain cases, noises, whistles, turbulence or vibrations. We strive throughout the product development and prototyping phases to minimize the sound and sensory impacts of adding such components. However, the aerodynamics, fuel consumption and noise tests of your vehicle manufacturer were performed with a “bare” vehicle, without any roof components. We are therefore not responsible for noises, whistles, vibrations, or turbulence caused by the addition of your roof components, nor for the increased fuel consumption of your vehicle.

! Do not overload your vehicle roof. Refer to your vehicle manufacturer’s load specifications for the maximum weights and heights to be respected. Overloading the manufacturer’s load limit will impact the center of gravity of your vehicle and might result in a change of the vehicle’s driving attitude, or in loss of control.

! Do not put more than 40lbs of weight directly over an unsupported part; for example at the rear end of the rack which is not supported by any roof mounts on the *Ford Transit 148-X*.

! Remora *Modular Roof Racks* are adaptation supports for recreational vehicle components (solar panels, cargo boxes, lighting components, etc.) or in some cases, for sports equipment. Any other use including the handling and moving of heavy objects at roof height, the installation of products or components not intended for these purposes or any leisure or maintenance operations made on your roof or roof rack is at your own risk.

! The design, manufacturing, installation and use of one or more supporting surface(s), finishing surface(s) or roof platform(s) that do not come from Remora co is at your own risk and may void the product warranty.

! Any modification or alteration of the *Modular Roof Rack* not approved by Remora co, or addition of components not designed or manufactured by Remora co may void the product warranty.

! At any time, if you have any doubts about the installation, stop immediately and contact us or an authorized installer.

## Preparation

Required tools and supplies

### Recommended supplies for installation

- Large blanket or large carton to protect the roof
- 8'+ stepladder

### Tools required for installation (not included)

- Measuring tape
- “Sharpie” felt pen or lead pencil
- Ratchet torque wrench (5Nm to 25Nm), extension & 1/2 ”& 9/16” deep sockets
- 3/16 ”& 7/32” “Allen” (Allen socket) bits for ratchet wrench
- Otherwise, “Allen” keys 3/16 ”& 7/32”
- Electric drill
- 1/8 ”metal pre-drill bit
- 11/32 ”metal bit

## Installation steps

## Installation steps

### Roof Mounts

#### A. Roof mount installation

**A1.** Insert (2X) carriage bolts in the square openings of the “U-shaped” adaptors, with the round bolt heads facing downwards. Slide the “U-shaped” adaptors from the center of the vehicle, outward. (“U” facing upwards)

- \* **Promaster 136 HR** : 6 mounts
- \* **Promaster 159 HR** : 8 mounts
- \* **Promaster 159”-X HR** : 10 mounts

**A2.** Insert the roof mount top adaptors on the “U-shaped” bottom adaptors, making sure the slotted holes are centered with the carriage bolts and that the adaptor visual openings are on the same side, facing outwards of the vehicle.



#### **WARNING !**

Make sure that the roof mount top adaptors have rubber edge trims applied on the lower sitting edges. If no rubber edge trims are present, stop installation immediately and contact Remora co customer service.

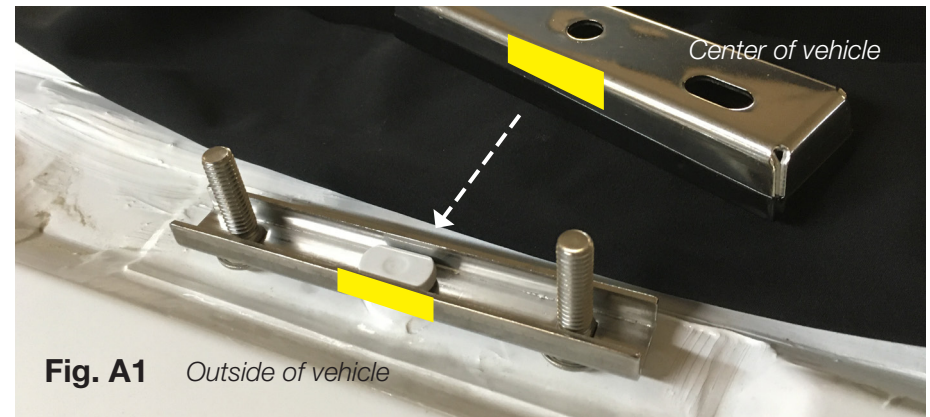

**Fig. A1** Outside of vehicle

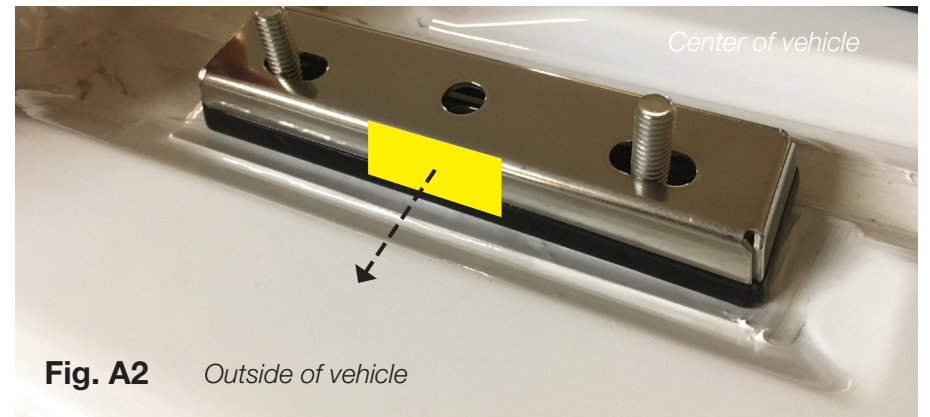

**Fig. A2** Outside of vehicle



# Installation steps

## Roof Mounts

Roof mount positioning diagram - RAM Promaster 159-X HR

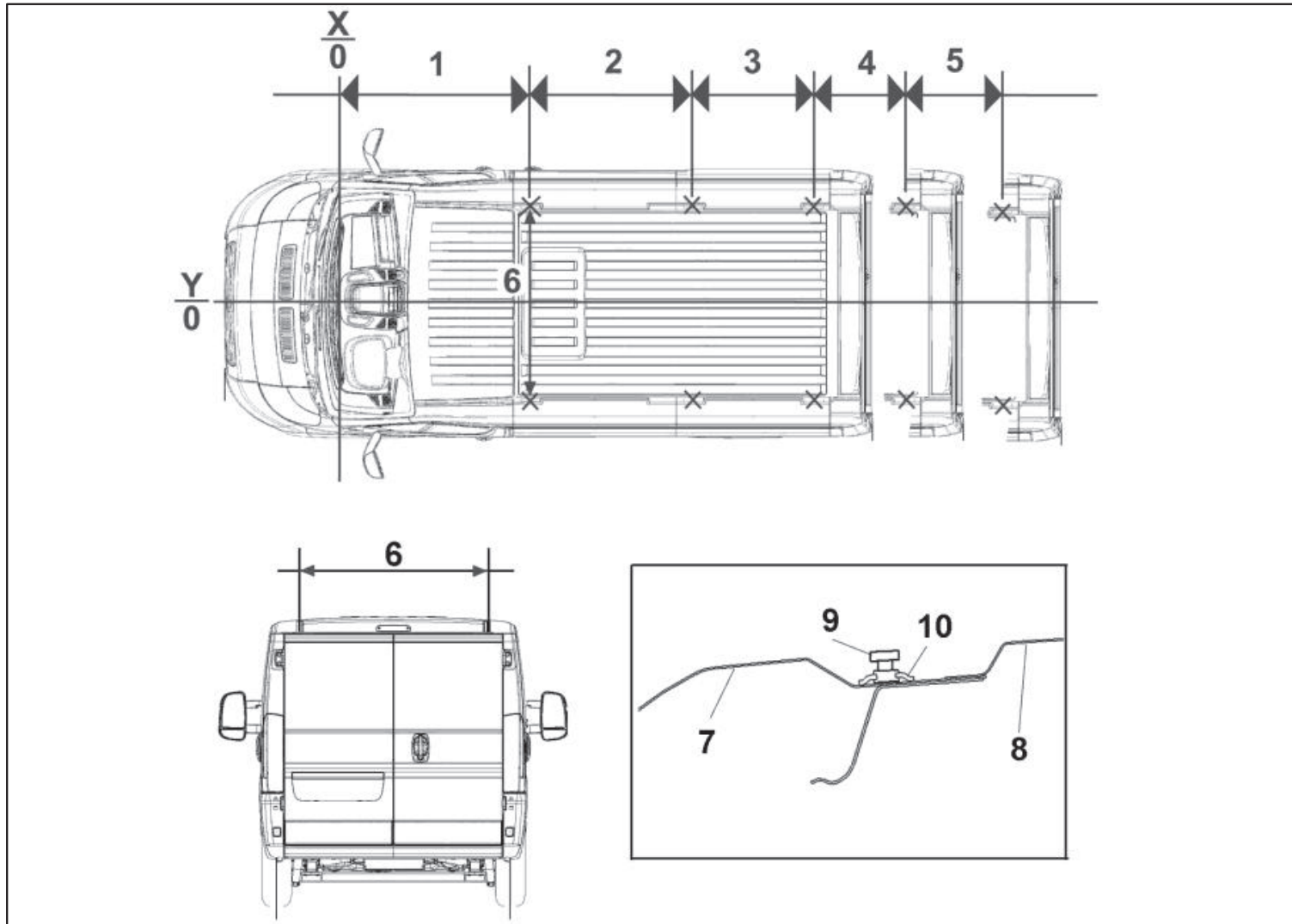

## Installation steps

### Roof Mounts

Roof mount positioning diagram - RAM Promaster 159-X HR

## ATTACHMENT POSITIONING

		Anchor point distances (mm)					'Y' distance (mm) (width)
		1	2	3	4	5	
	Load anchor point positions						6
	Short wheelbase, low roof van (L1H1)	1392.8	1244.7	920,5	-	-	740.0
	Medium wheelbase, low roof van (L2H1)	1392.8	1414.7	1201	-	-	740.0
136	Medium wheelbase, high roof van (L2H2)	1392.8	1414.7	1193.5		-	740.0
159	Long wheelbase, medium roof van (L4H2)	1392.8	1414.7	713.5	1065	-	740.0
159-X	Extra long wheelbase, medium roof van (L5H2)	1392.8	1414.7	713.5	716	714	740.0

## Installation steps

### Side Plates

## B. Side plate installation

**B1.** Place the side panels on the roof anchors previously installed in steps A, starting with the front panels and working your way towards the rear. Refer to the “*Positioning Diagram*” on the next page or to the diagram provided by Remora for your custom project. The side panels are identified with a label on the inside.



### **WARNING !**

Loosely-fitted side panels can slip, fall and damage your vehicle. Do not leave them unsecured.

**B2.** Add the washers and nuts provided and tighten lightly on the anchor bolt threads, by hand. Stop tightening before the nylon inserts of the nuts reach the bolt threads. At this point we just want to secure the panels to prevent them from falling. **\*\* DO NOT TIGHTEN THE NYLOCK NUTS - These nuts are for one time use only; it is necessary to avoid tightening and loosening them. \*\***

\* It is important to leave some slack in the nuts at this time, to allow the cross members to be inserted from the top of the roof rack later on.

\*\* The final tightening will be done later.



Fig. B1

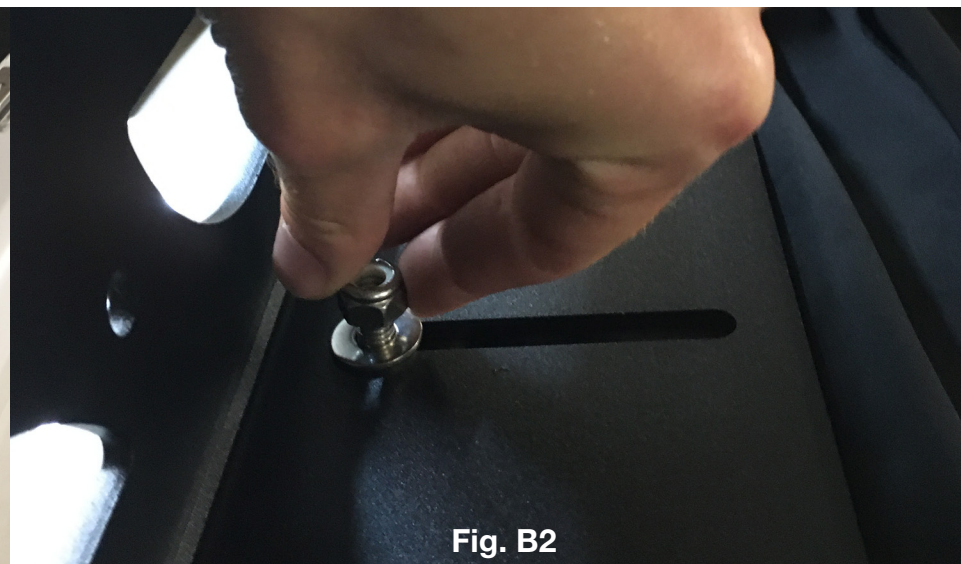

Fig. B2

# Installation steps

## Side Plates

Side plate positioning diagram - RAM Promaster 159-X HR

(Passenger side plates in transparency here.)



## Installation steps

### Side Plates

#### B. Joiner plate installation

**B3.** Repeat with the front and rear side panels on other side, if not already done.

\* Quantity and length of panels may vary depending on your format.

**B4.** Install the joiner plates inside the rack, at the joints of the various side panels, using the bolts, nuts and washers included. Allow a gap of 1/16" to 1/8" between two adjacent panels. You can wait until the very end to do the final tightening. This will give you a little more flexibility during the installation of the crossbars and solar panels.

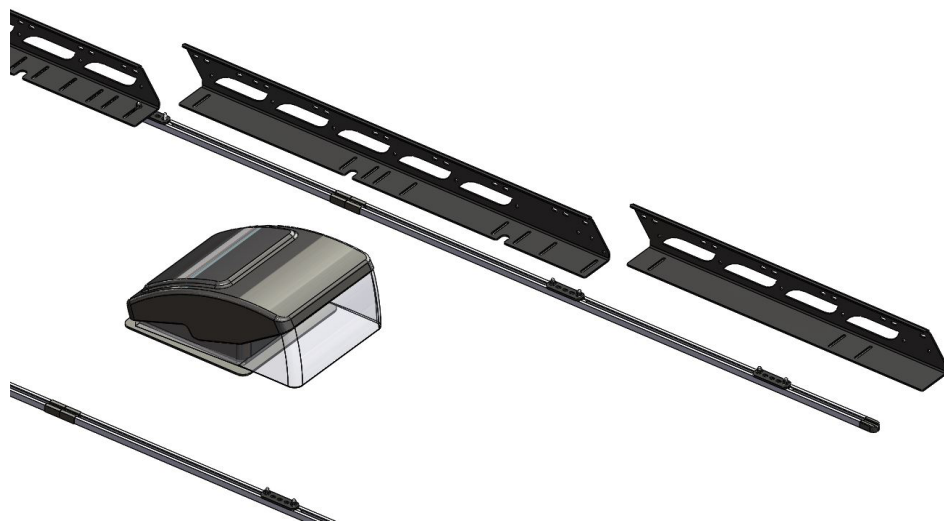

**Fig. B3**  
(Mercedes Sprinter 170 shown here)

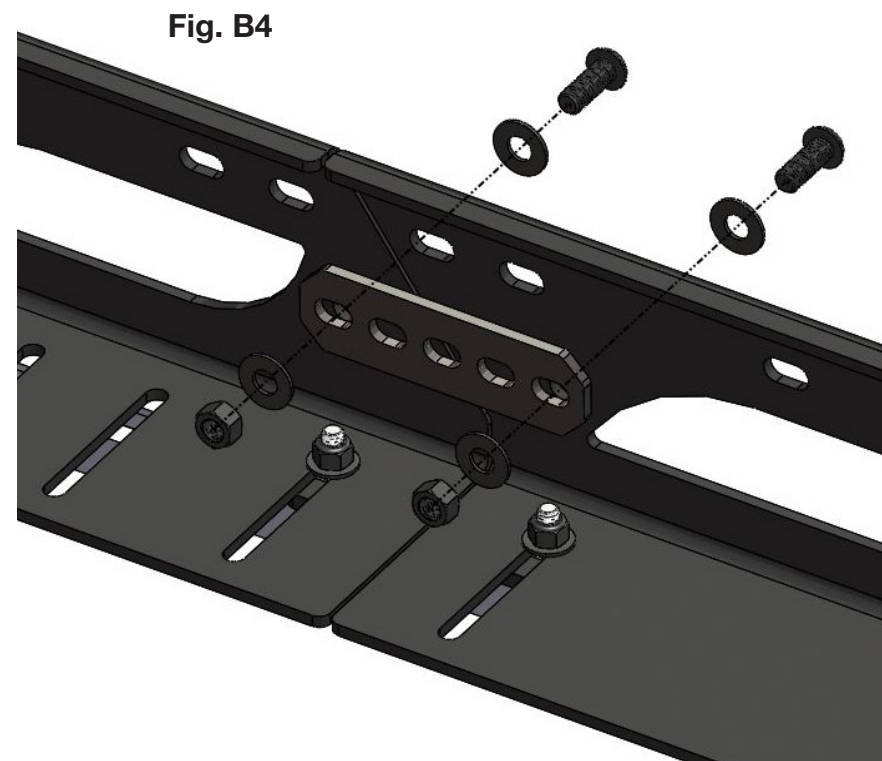

**Fig. B4**

## Installation steps

### Solar panel & crossbar installation

#### C. Solar panel & crossbar installation

➔ **NOTE :** If you're not installing solar panels at this moment, you can skip to page 18.

**C1.** Determine the position of your roof components and solar panels beforehand. We do offer 3D analysis and roof layout design services to help you with the positioning of your roof components. Don't hesitate to contact us for more details.

**C2.** Calculate and drill 2 holes per short side on a 100W panel or 4 holes per long side on a 300W panel for width assembly. In order to install your solar panels "flush-mount" with the top of your crossbars, calculate  $\frac{3}{4}$ " from the top of your solar panel (side with the cells) for the positioning of the holes. Pre-drill with a  $\frac{1}{8}$ " drill bit and then with an  $\frac{11}{32}$ " drill bit.



#### **CAUTION !**

Some panels have a thicker top cell layer than others. Take the necessary measurements inside of the panel and precautionary measures while drilling to make sure you do not drill too close to the cells. You must have space inside your panel to install the  $\frac{5}{16}$  "x  $\frac{3}{4}$ " long bolts and washers included in the "Solar Panel Hardware" kit.

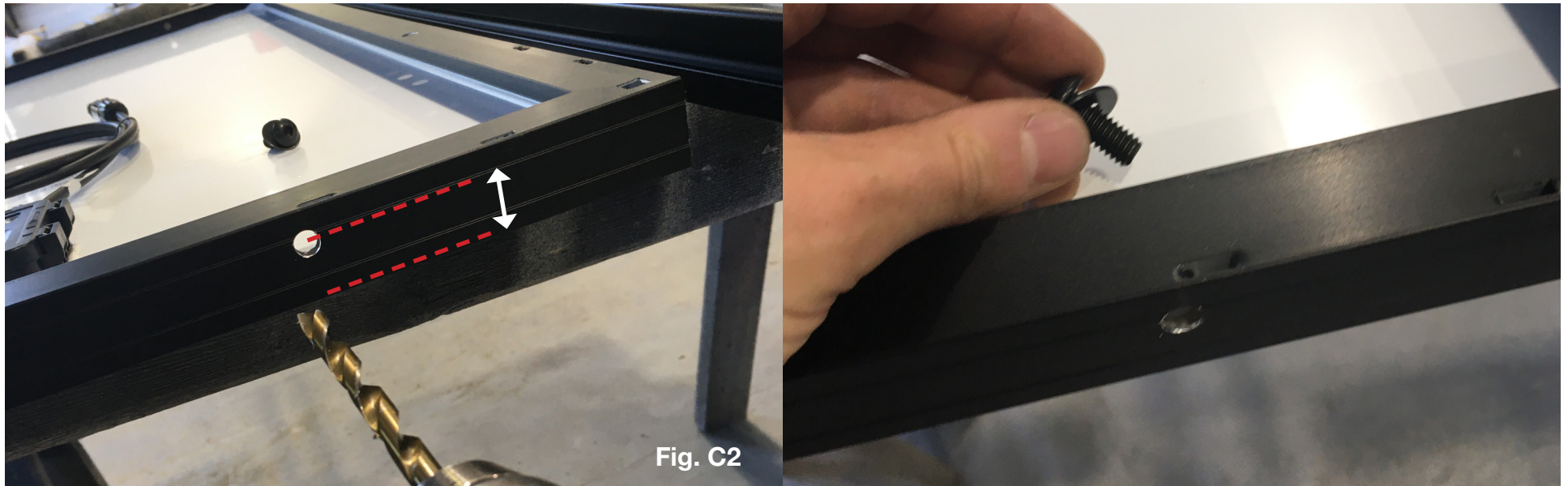

Fig. C2

## Installation steps

### Solar panel & crossbar installation

#### C. Solar panel & crossbar installation

**C3.** Apply a drop of Loctite Blue on the end of the 5/16-18 x 3/4 bolts and screw the “T-Nuts” onto the bolt thread protruding outside of the solar panel(s), installed in step C2. Do not tighten them all the way. Leave about 3/16 “to 1/4” clearance between the outside of the panel and the “T-Nuts”.

**C4.** Slide a crossbar on each side of your panel(s), making sure the “T-Nuts” slide into the crossbar grooves.

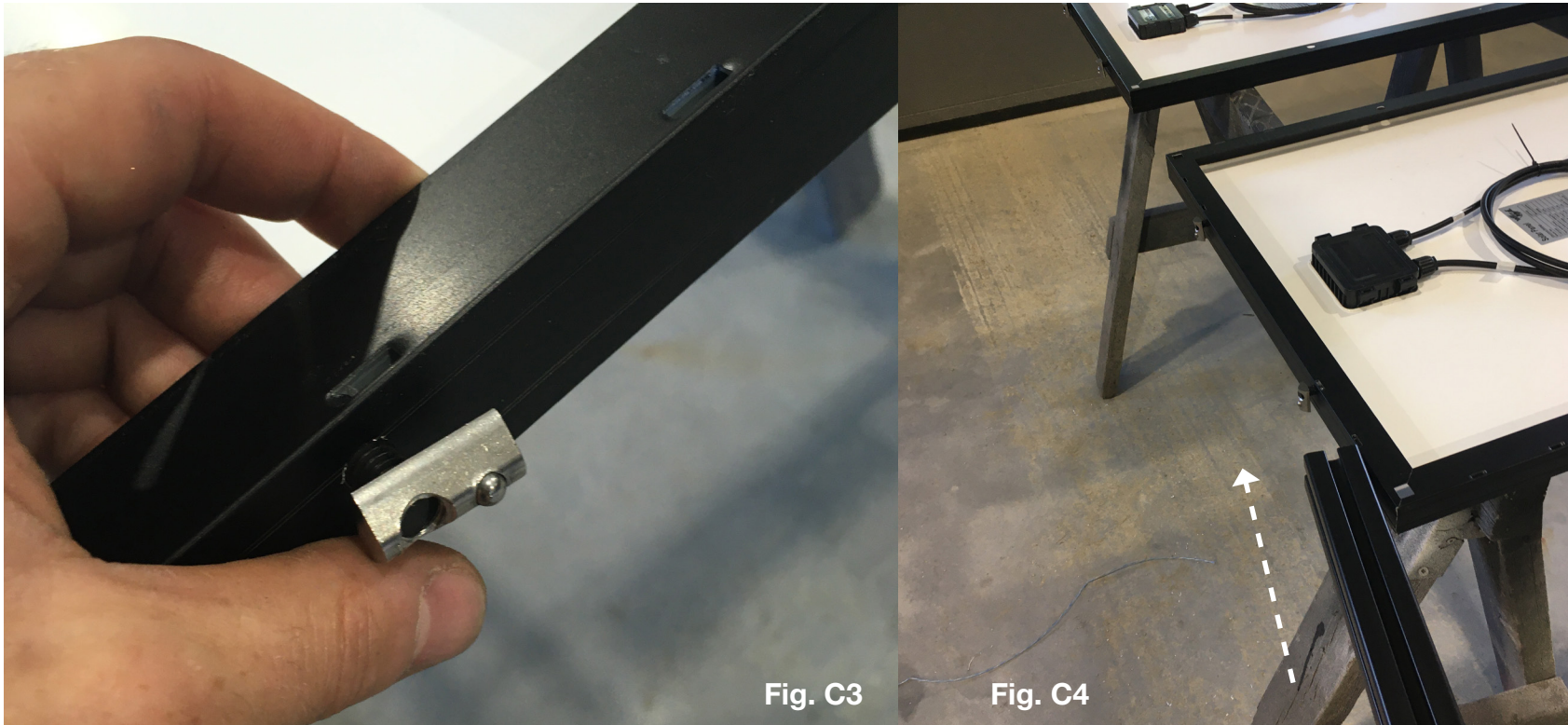

Fig. C3

Fig. C4

## Installation steps

### Solar panel & crossbar installation

#### C. Solar panel & crossbar installation

**C5.** If needed, measure the required spacing between your panels according to the positioning and clearance of your different roof components. (Maxxfans, antennas, etc.)

**C6.** Once the positioning and alignment of your panels is complete, tighten (by hand) the 5/16" x 3/4" long bolts located inside the solar panels.

\* Perform a final tightening for this step - you will not have access to this hardware afterwards.

Tightening torque : Torque to **7Nm / 4 pi-lb** for double-sided aluminum wall solar panels, with a minimal wall thickness of 0.042".

**(Do not forget to apply a drop of Blue Loctite on the tip of these screws).**

For panels with walls thinner than 0.042", contact your solar panel manufacturer to validate the installation method.

**C7.** Lay the solar panels (fitted with crossbars) and unused crossbars on the vehicle roof, being careful not to scratch your roof.



#### **CAUTION !**

Depending on the size of your panel(s), we recommend asking help during this step. Some panels or panel assemblies can be very heavy.



Fig. C5



Fig. C6



## Installation steps

### Solar panel & crossbar installation

#### C. Solar panel & crossbar installation

**C8.** Apply a drop of Loctite Blue to the end of the 3/8 "x 1" bolts provided for the installation of the crossbars ("Crossbar ends hardware" kit) as well as on the 5/16 "x 5/8" bolts provided for the installation of the deflector brackets. ("Wind fairing hardware" kit).

\* No need to apply a large amount of Loctite. One medium-sized drop per bolt is sufficient.

**C9.** Identify the right position for your solar panel(s) and place them on the inside of the side panels. It is preferable to have a partner for this step. Use the 1 1/2" thick cardboard blocks at the extremities of the rack packaging box to temporarily set your panel(s) on. These will raise the panels at the height needed for their installation.

**C10.** Use the 3/8 "x 1" bolts and washers from the "Crossbar ends hardware" kit and torque down the crossbars. Refer to page 21. **Torque to 19Nm.**



#### CAUTION !

When adding or repositionning crossbars, clean the bolt threads and add a drop of Loctite Blue before reinstallation.

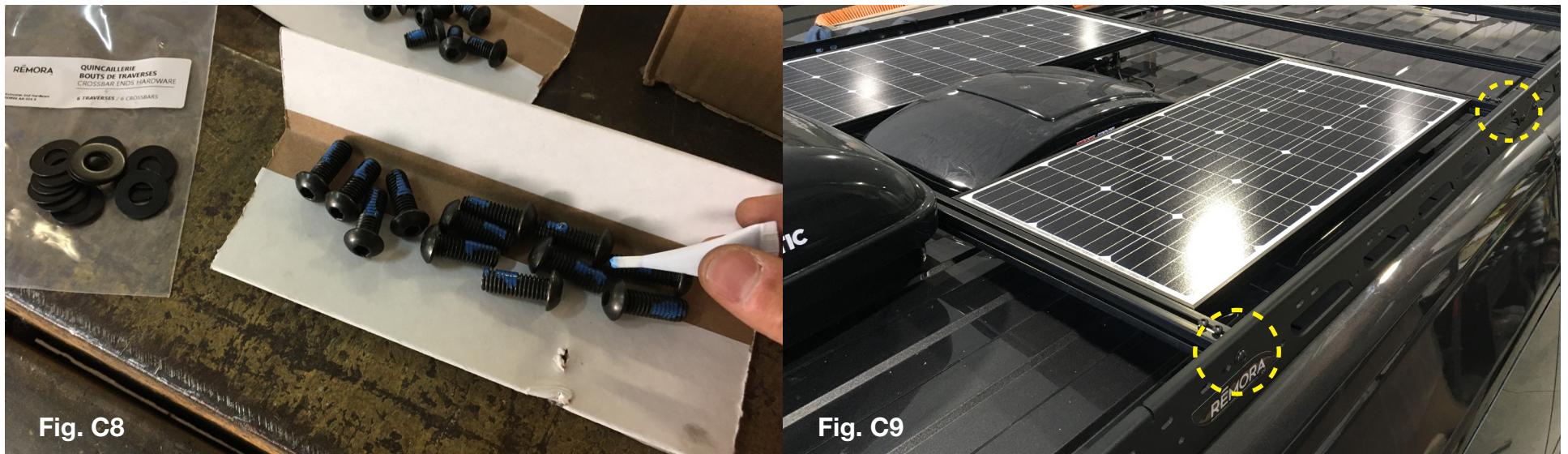

Fig. C8

Fig. C9

## Installation steps

### Wind fairing brackets

#### D. Wind fairing bracket installation

**D1.** Place an unused crossbar on a worktable or level ground. Place your deflector on top, centered lengthwise with the crossbar, the slotted holes directly located on the edge of the crossbar.

**D2.** Once properly centered, make a line using a pencil or felt-tip pen in the center of the slotted holes on your crossbar. These lines will determine the centers of your fairing brackets.



## Installation steps

### Wind fairing brackets

#### D. Wind fairing bracket installation

**D3.** Place 4X “T-Nuts” in the groove of the crossbar and line up the “T-Nut” hole with your marks made at step D2.

**D4.** Place the 4X fairing brackets on the flat surface of the crossbar and assemble using the bolts and spacers provided for this purpose. (“Wind fairing hardware” kit). Make sure the brackets are centered with your marks / lines. Apply a drop of Loctite Blue on the tip of the screws.  
\* Perform final tightening for this step - however, you will be able to adjust this hardware later, during final tightening. **Torque to 15Nm.**

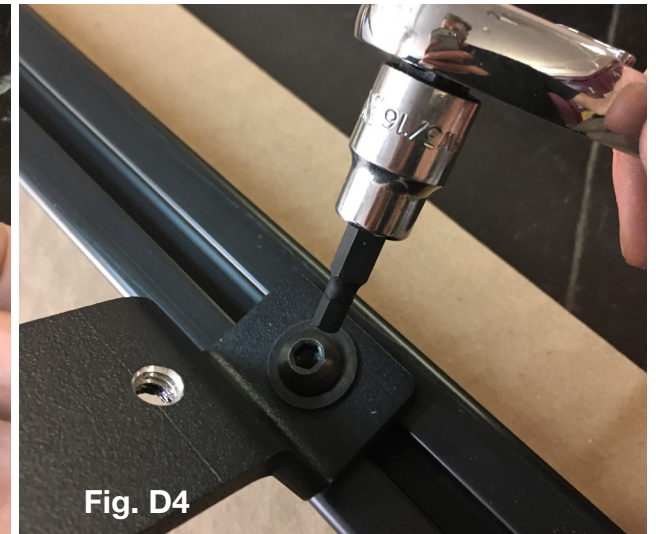

## Installation steps

### Crossbars

#### E. Crossbar tightening

**E1.** Once your crossbars are on the roof of the vehicle, position them according to your roof layout planned in advance.

**E2.** Secure them at both ends using the 3/8 "x 1" bolts and washers provided for this purpose, to which Loctite has been applied in step C8.

\* It is normal for the side panels to straighten out when tightening the cross members. A final alignment and tightening of the side panels on the roof mounts will be performed next.

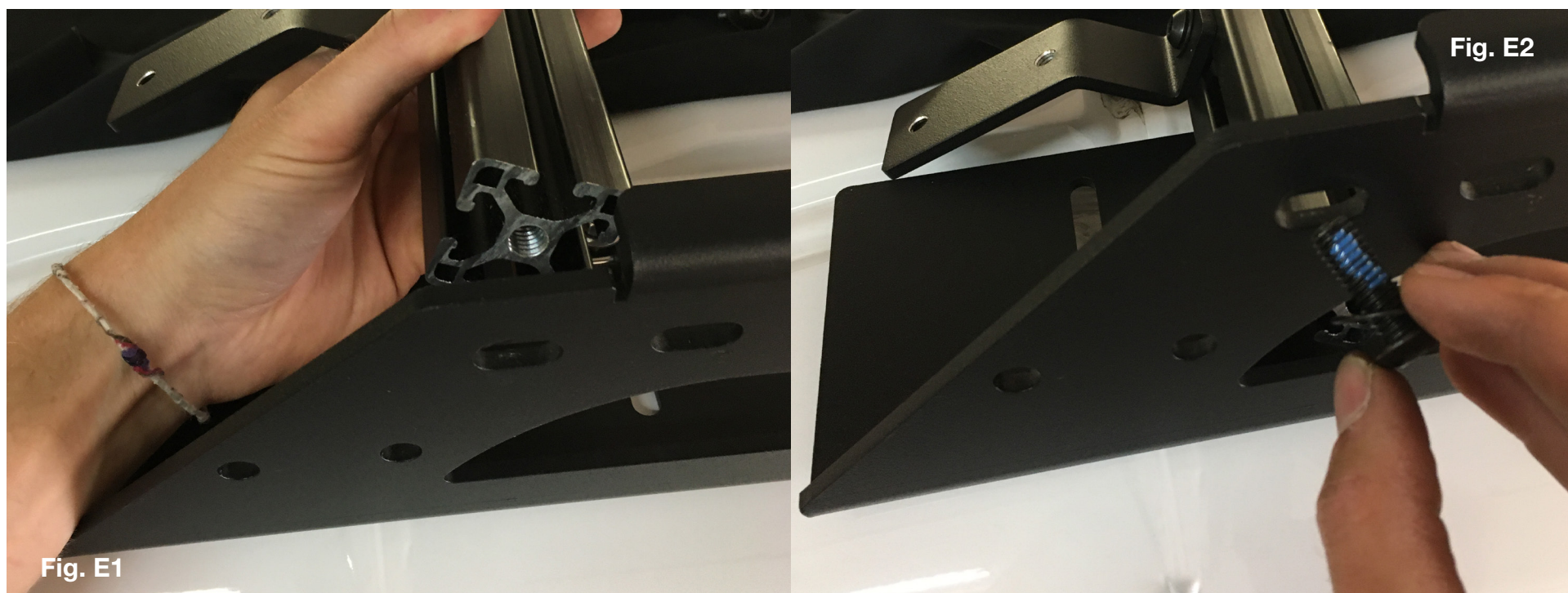

## Installation steps

### Final tightening

## F. Alignment & final tightening

**F1.** Adjust the lateral alignment of your roof rack by placing your stepladder at the front and rear of the vehicle. You can also rely on the symmetrical edges and details of the vehicle's body to perform the alignment.

**F2.** Perform the final tightening of the joiner plates (3/8" x 1 screws & NyLock nuts - Ref. p.14 - Fig. B4). At this stage, you can adjust the flatness between the adjacent side panels. Make sure the top edge of both side plates is at the same height (1/16 - 1/8" variation is acceptable).

**Tightening Torque : 27 Nm / 20 pi-lb**

**F3.** Verify / Torque down the crossbars if not already done. (3/8" x 1 screws - Ref. p.20 Fig. E2).

**Tightening Torque : 19 Nm / 14 pi-lb**

**F4.** After the lateral alignment is done and the rack is positioned symmetrically, torque down the side plates to the roof mounts taking care of aligning and straightening the carriage bolts installed at step A1 in the side panel holes. (5/16 NyLock Nuts - Ref. p.11 Fig. B2).

**Tightening Torque : 15 Nm / 8 pi-lb**



**\*\* VERIFY AND ADJUST, IF NECESSARY, THE ROOF MOUNT TORQUE (NYLOCK NUTS) AFTER 1 & 6 MONTHS, AND ONCE A YEAR AFTERWARDS.**



### **WARNING !**

Overtorquing the roof mount nylock nuts can cause your OEM roof anchor points to delimitate and provoke water infiltration and rust. DO NOT OVERTORQUE.



### **WARNING !**

Tightening the nuts on crooked bolts can cause them to crack or completely break. The carriage bolts must be straight before torquing down to proper torque.



### **WARNING !**

Do not tighten and loosen Nylock lock nuts more than once, as this may crack or break the bolts. Nylock lock nuts are for single use only. The final tightening must therefore be done only once.



### **SUBSEQUENT INSTALLATION**

If you plan to remove the roof rack for a second installation on another vehicle, contact the Remora team for the necessary roof mounts and / or replacement hardware (Nylock nuts). Nylock lock Nuts must not be reused for a second installation.

## Installation steps

“T-Nuts”

### G. “T-Nuts” installation on crossbars

**G1.** Place the remaining “T-Nuts” in the upper groove of the crossbars, depending on your roof layout or the positioning of your accessories. It will be possible to move or remove these “T-Nuts” by hand if necessary.

**G2.** Insert a 5/16 "x 5/8" screw (with a drop of Loctite Blue applied to the end of the screw) and washer through these “T-Nuts” and tighten. (“T-Nuts hardware” kit).

Tightening Torque : Refer to your accessory / component installation manual. MINIMUM Torque for unused T-Nut : 8 Nm / 5 pi-lb.



#### NOTE

If you don't have any accessories or roof components to install at this time, do not install a washer before the screw; they will be loose and noisy. Only tighten the screw without a washer for an unused T-Nut, or wait till the installation of additional roof components.

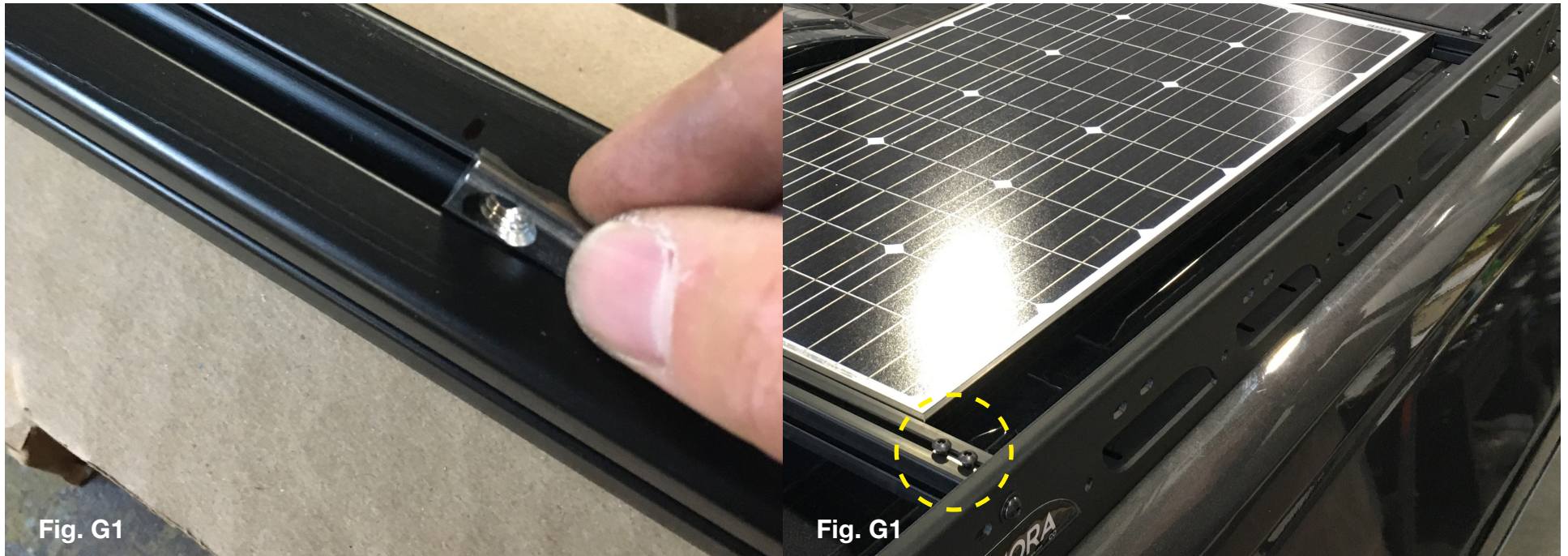

## Installation steps

### Wind fairing installation

## H. Wind fairing installation

**H1.** Temporarily place the fairing over the wind fairing brackets, checking for correct hole alignment. Adjust the lateral positioning of these brackets if needed in order to obtain “center-center” alignment. Perform final tightening of the brackets if not already done. **Torque to 15Nm.**



### **WARNING !**

After installation, the wind fairing should not, in any case, be touching to roof's body.

If the wind fairing is touching the roof's body, stop the installation immediately, go back and validate previous installation steps to insure proper side plate positioning and contact Remora's customer service.



### **WARNING !**

Adding extra weight to the front crossbar, off-roading, the lack of Loctite applied to the front crossbar's hardware or improper torquing may cause the wind fairing to slightly rotate. Occasionally verify the wind fairing's position to ensure that it is not touching the roof's body.



F11 & H4

## Installation steps

### Wind fairing installation

#### H. Wind fairing installation - **\*\* PRE 2021 ROOF RACKS ONLY \*\***

**H3.** Being careful not to touch the adhesive side, remove the adhesive liner of the *Paint Protection Films* (provided in the “*Wind fairing hardware kit*”) and glue the adhesive side of these two films at the positions identified in step H2. To avoid creating air bubbles or pockets that can collect water and debris, crush the film by rolling a small cylindrical object (pencil) from the center to the ends of the film.

**H4.** Install the 5/16-18 5/8” wind fairing bolts and washers provided (“*Wind fairing hardware kit*”), on which a drop of Loctite Blue has been applied beforehand, at point D4. Perform a final tightening by hand, thereafter. (Refer to Fig. H1-H4) **Torque to 4Nm.**

**\*\* DO NOT OVERTIGHTEN, THE FAIRING NEEDS SPACE FOR ITS THERMAL EXPANSION, WHEN ORIENTED TOWARD THE SUN. STOP TIGHTENING WHEN THE WASHERS TOUCH HE FAIRING. \*\***



#### **WARNING !**

Make sure that once the fairing is installed, no edge or section of the component touches the bodywork.

Only the two rubber protectors present on the lower edge of your wind deflector should touch the *Paint Protection Films* previously applied in step H3.

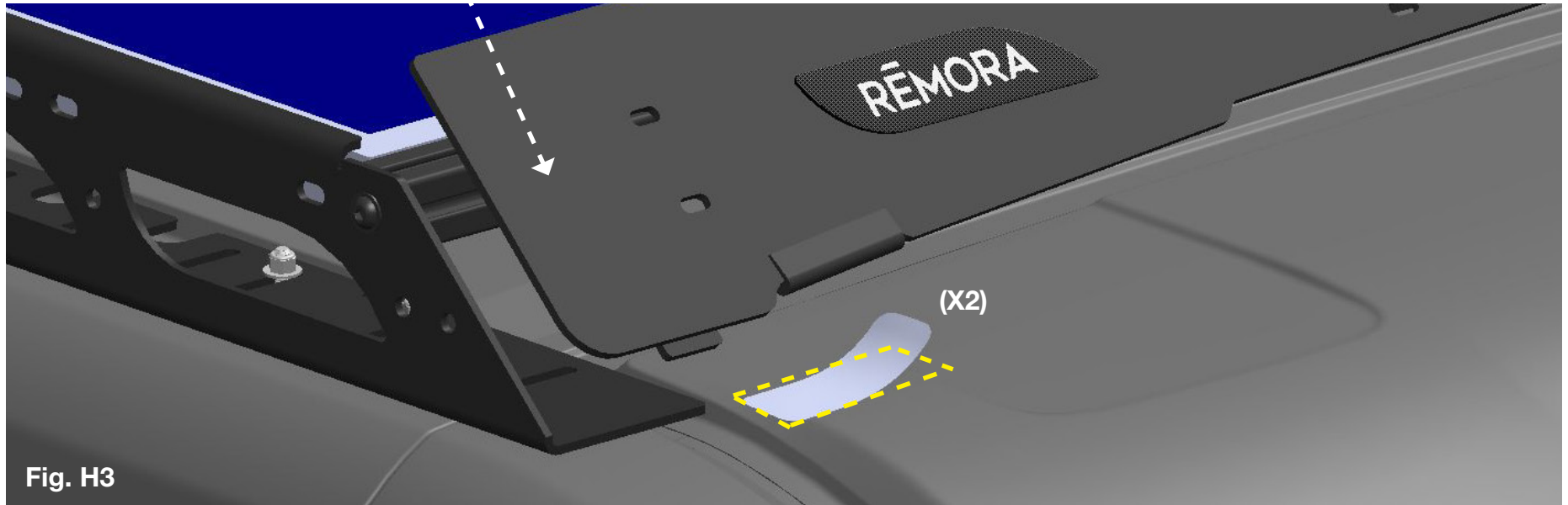

Fig. H3



**REMORA CO inc.**  
2590 Boulevard Industriel  
Chambly QC J3L4V2

info@remoraco.com

**WWW.REMORACO.COM**

©2020 Remora co inc. Information subject to change without notice.  
Doc # : Remora\_MFR110\_Ford Transit 148-X-HR\_eng  
rev100 - 2021-01-02

